



프리미엄효율 (Premium Efficiency)

P Series 3-Phase Foot(Leg) Mounted Type

1.5kW

■ SPECIFICATION

■ MOTOR

프레임 형번 Frame No.	출력 Output (kW)	기종명 Model Name	극수 Poles	전압 Voltage (V)	주파수 Freq. (Hz)	사용 조건 Duty	정격 부하 [Rated Load]					보호 등급 Degrees of protection	절연 등급 Insulation Classification	냉각 방식 Protective Cooling System	
							전류 Current (A)	속도 Speed (r/min)	토크 Torque (kgf·cm)	역율 Power Factor(p.u.)	효율 Efficiency (%)				
90L	1.5	PPGF150-2R4L□□	2	220/380	60	CONT.	5.65/3.25	3515	41.5	0.81	86.6	IP55	F	Totally Enclosed Fan-Cooled	
							5.50/3.20	2915	50.0	0.79	84.2				
		PPGF150-2U6L□□	2	230/400	50		3.00	3500	48.5	0.82	86.6				
							5.90/3.40	1760	82.9	0.78	86.5				
		PPGN150-4R4L□□	4	220/380	60		50	5.90/3.40	1470	99.3	0.72				85.3
								3.35	1760	96.6	0.76				86.5
112M		PPJL150-6R4L□□	6	220/380	60	7.7/4.45	1175	123	0.6	88.5					
						7.1/4.1	980	148	0.6	82.5					
		PPJL150-6U6L□□	6	230/400	50	3.75	1175	145	0.65	88.5					

- Note) • Foot(Leg) Mounted Type 과 Flange Mounted Type 제품은 특성이 동일합니다.
(Foot (Leg) Mounted Type and Flange Mounted Type have the same specifications)
• 전압 U6 모델의 실제 정격출력은 230V/400V 50Hz에서 1.5kW, 460V 60Hz에서 1.75kW입니다.
(Actual rated power for voltage U6 model is 1.5kW at 230V/400V 50Hz and 1.75kW at 460V 60Hz)

■ PE-L Type DIMENSIONS [Foot(Leg) Mounted Type]

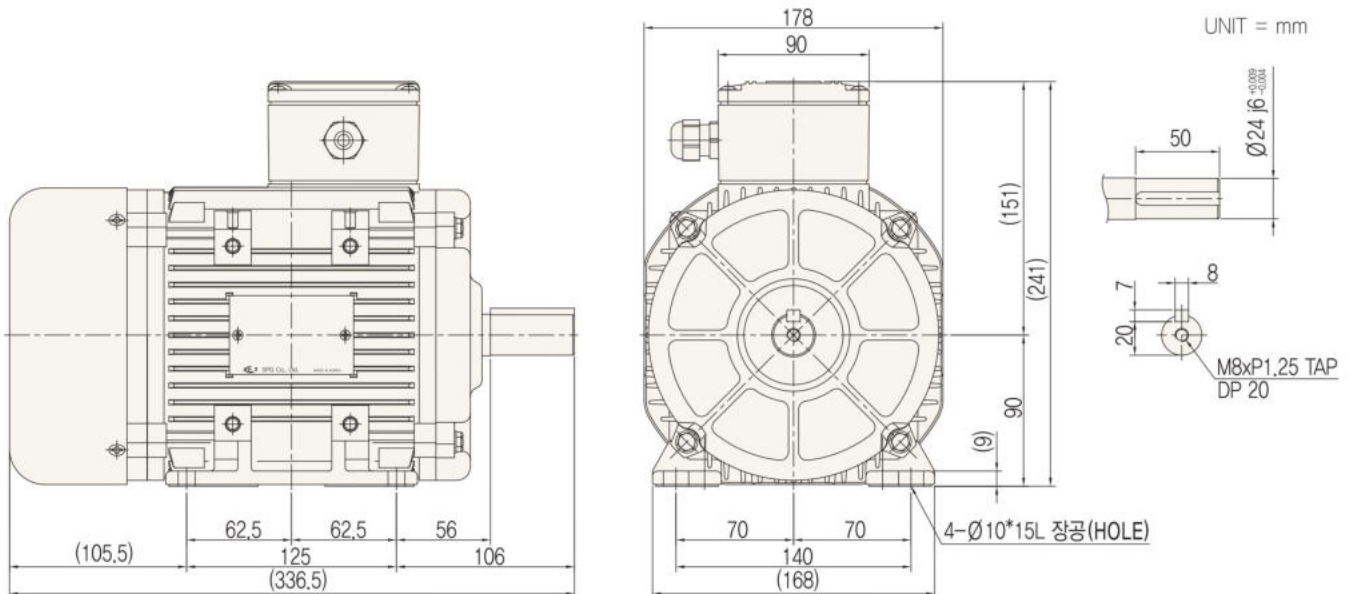

- Note) • 키 및 키홈 공차(Key and Key groove tolerance) : KS B 131
• 제품의 전체 높이 치수는 분리형 다리(Foot)의 부착 위치에 따라 달라집니다.
(The total length of the products may vary depending on the mounting position of the discrete foot.)
• 출력축 ØD공차(ØD tolerance for output shaft) : KS B 0401

Bearing No.		Weight
Load	Unload	
6205ZZ	6204ZZ	18.3kg

기종명 (Model Name) Coding
9Page

출력축 사양 (Specification for output shaft)
30Page

기술자료 (Technological Data)
101Page